

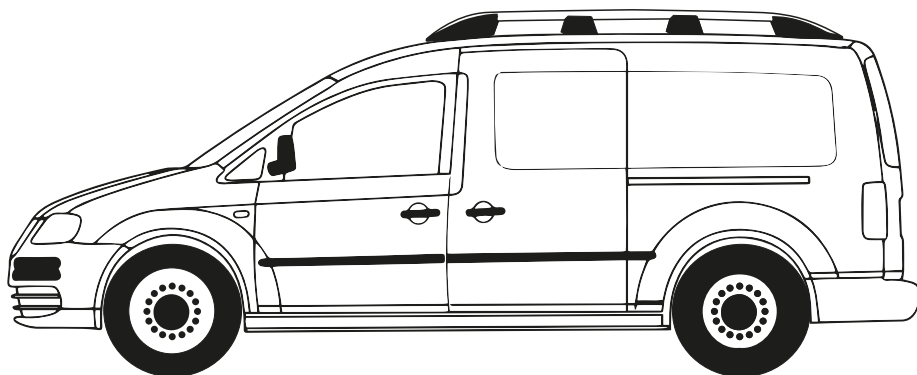

ONTEC

AUTO ACCESSORIES.CO



VW Caddy Maxi 2003>

CZ	Montážní návod :	HAGUSY
GB	Fitting Instructions :	ROOF RACK
D	Montageanleitung :	DACHRELING
F	Instructions de Montage :	RIDELLES DE TOIT

CZ

Nosnost střešního nosiče je maximálně 75 kg. Před zatížením střešního nosiče zkontrolujte maximální nosnost střechy vašeho vozidla, kterou udává výrobce automobilu.

GB

*Roof Rack carrying capacity is maximum 75 kg. Please check your vehicle roof maximum carrying capacity from your car manufacturer before load roof rack.

G

*Maximale Traglast unsere Dachrelinge betragen 75kg. Die freigegebenen Dachlasten der Fahrzeughersteller dürfen nicht überschritten werden. Bitte zur Kenntnisnahme!

F

*La capacité de chargement maximale est de 75 Kg. Nous vous prions de vérifier la capacité de chargement du toit de votre véhicule avant de charger les barres de toit.



30 Min.

①



10.08.2021 - M7520930L

Obsah balení

Part List / Teileliste / Lista de accesorios

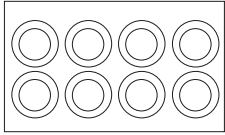

- (CZ) Podložka = 8 ks
- (GB) RING WASHER = 8 PIECES
- (D) UNTERLEGSSCHEIBE = 8 STÜCK
- (F) RONDELLE AUTOBLOQUANTE = 8 PIÈCES

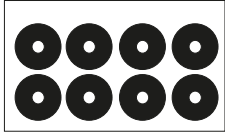

- (CZ) Gumové těsnění = 8 ks
- (GB) IMPERMEABLE RUBBER = 8 PIECES
- (D) KUNSTSTOFF-DICHTUNG = 8 STÜCK
- (F) JOINT EN PLASTIQUE = 8 PIÈCES

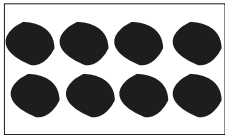

- (CZ) Plastová zásepka = 8 ks
- (GB) PLASTIC PLUG = 8 PIECES
- (D) GUMMISTOPFEN = 8 STÜCK
- (F) BOUCHON PLASTIQUE = 8 PIÈCES



	=	<table style="margin: auto;"> <tr><td>Max.</td></tr> <tr><td>75 kg</td></tr> <tr><td><hr style="width: 50%; margin: 0 auto;"/></td></tr> <tr><td>Max.</td></tr> <tr><td>165 lbs</td></tr> </table>	Max.	75 kg	<hr style="width: 50%; margin: 0 auto;"/>	Max.	165 lbs
Max.							
75 kg							
<hr style="width: 50%; margin: 0 auto;"/>							
Max.							
165 lbs							

--	--	--

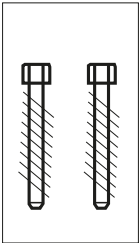

m-8 x 45 (přední - 2ks)

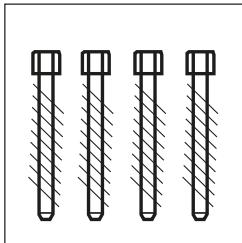

m-8 x 70 (prostřední - 4ks)

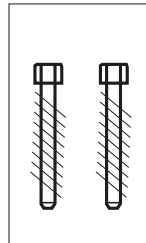

m-8 x 45 (zadní - 2ks)

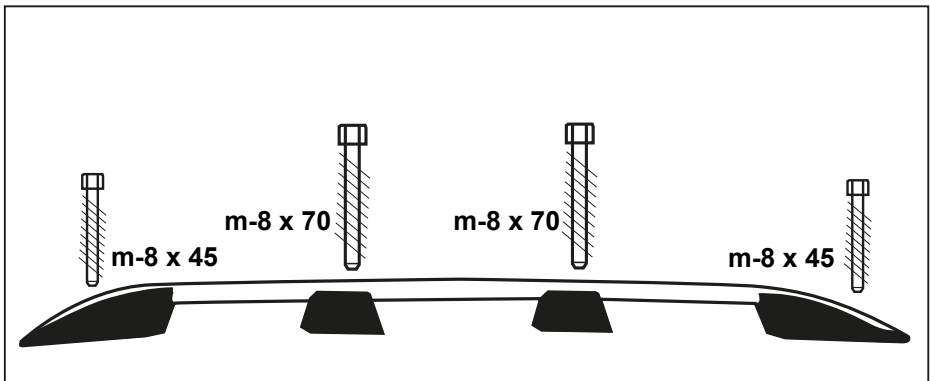
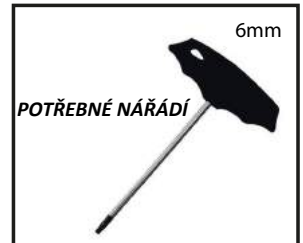

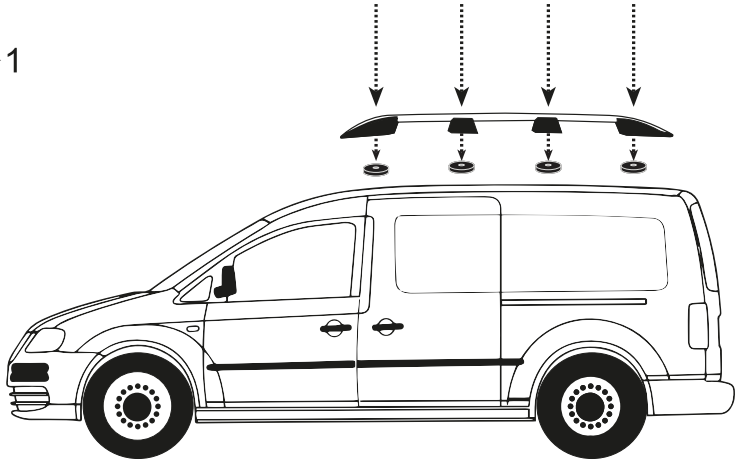
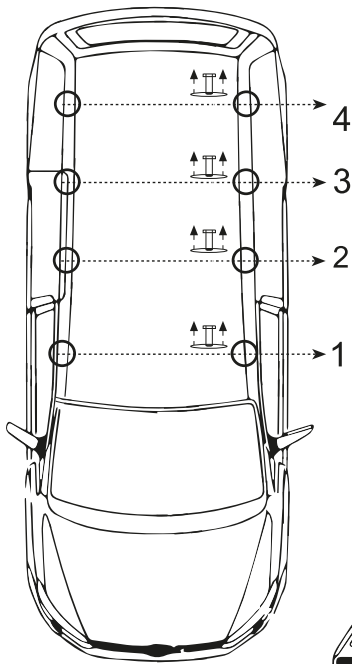

1) Po odšroubování a vytažení původních šroubů vozidla, abyste předešli problémům s netěsností, sloupněte krycí folii gumového těsnění a nalepte jej kolem každého odhaleného závitu.

1) Please take the plugs (Number 1-2-3-4) out and stick the seals to their empty places.

1) Entnehmen Sie die 1 bis 4 Nr. Kappen vom Dachfahrzeug und legen Sie die wasserundurchlässige Dichtung rauf.

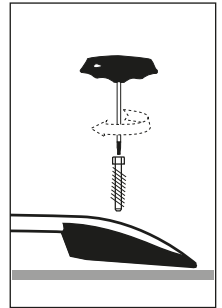
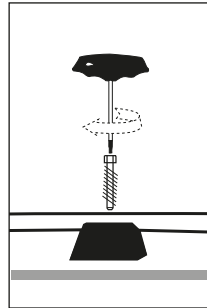
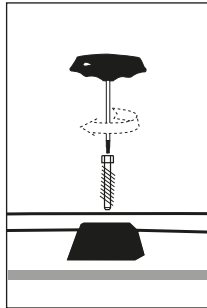
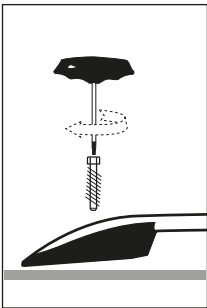

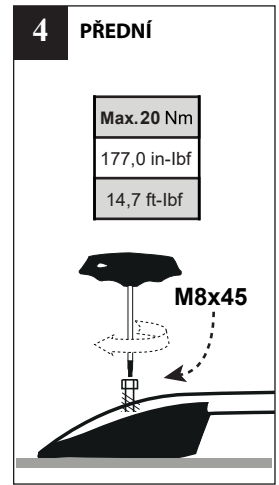
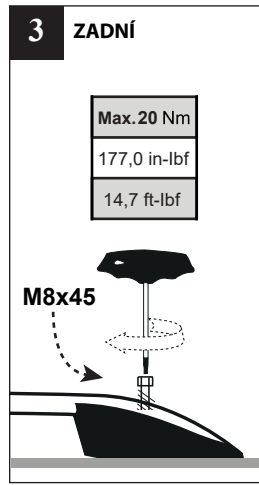
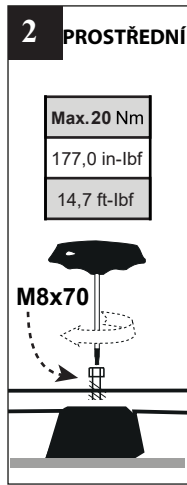
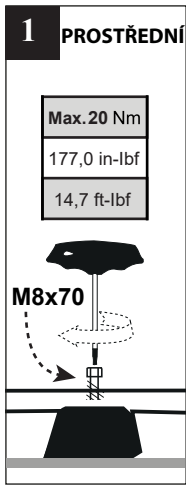

2) Upevněte hagasy v upevňovacích bodech na horní části vozidla, poté začněte otáčet šrouby v následujícím pořadí (Šroub #1, Šroub #2, Šroub #3, Šroub #4) a otočte šrouby stejnou silou, maximálně 20 Nm.

2) Fix the roof rail at the mounting points on top of the vehicle then start turning the screw bolts in the following order (Bolt #1, Bolt #2 , Bolt #3, Bolt #4) and turn the bolts by putting equal force, maximum 20 Nm.

2) Positionieren Sie die Dachreling an den Befestigungspunkten oben auf dem Fahrzeugdach und beginnen Sie dann, die Schraubenbolzen in der folgenden Reihenfolge zu drehen (Schraube #1, Schraube #2, Schraube #3, Bolt #4) und drehen Sie die Schrauben mit gleicher Kraft, die maximale Kraft sollte 20 . betragen Nm.

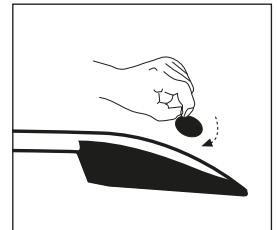
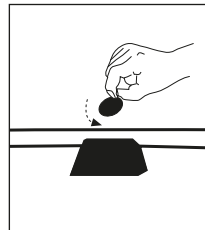
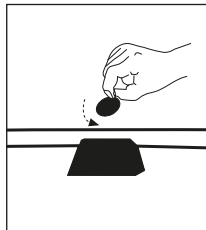
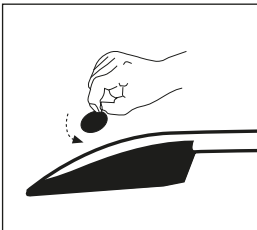

3) Umístěte gumové záslepky.

3) Tap the plugs on roof rails.

3) Stecken Sie die Stopper in Ihre Plätze und schließen Sie diese.